

SEC *Signature DIR* Process Monitor

Instruction and Operation Manual

Sensor Electronics Corporation
5500 Lincoln Drive
Minneapolis, Minnesota 55436 USA
(952) 938-9486 Fax (952) 938-9617
email sensor@minn.net or www.sensorelectronics.com

Sensor Electronics Corporation

Sensor Electronics Corporation (SEC) is an innovative manufacturer of fixed system gas detection equipment, for combustible gases, oxygen and toxic gases.

Commitment

Our quality and service are uncompromising. We back each of our products with a two-year warranty on all materials and workmanship. We offer technical support, user training and on-site service and maintenance of equipment to meet the needs of our customers.

Gas Detection Service

Individually designed maintenance packages are available for specific customer needs. Service begins with verification of the system installation that includes an initial system check and calibration. We then offer customer training programs (on-site and at factory) to insure that technical personnel fully understand operation and maintenance procedures. When on-the-spot assistance is required, service representatives are available to handle any questions or problems immediately.

Warranty

Sensor Electronics Corporation (SEC) warrants products manufactured by SEC to be free from defects in workmanship and materials for a period of two (2) years from date of shipment from the factory. Any parts returned freight pre-paid to the factory and found defective within the warranty will be repaired or replaced, at SEC's option. SEC will return repaired or replaced equipment pre-paid lowest cost freight. This warranty does not apply to items which by their nature are subject to deterioration or consumption in normal service. Such items may include:

Fuses and Batteries.

Warranty is voided by abuse including rough handling, mechanical damage, alteration or repair. This warranty covers the full extent of SEC liability and SEC is not responsible for removal, replacement costs, local repair costs, transportation costs or contingent expenses incurred without prior written approval. Sensor Electronics Corporation's obligation under this warranty shall be limited to repair or replacement of any product that has been returned to Sensor Electronics Corporation for warranty consideration. This warranty is expressly in lieu of any and all other warranties expressed or implied, and all other obligations or liabilities on the part of Sensor Electronics Corporation including but not limited to, the fitness for a particular purpose. In no event shall Sensor Electronics Corporation be liable for direct, incidental, or consequential loss or damage of any kind connected with the use of it's products or failure to function or operate properly.

Year 2000 Compliance

All Sensor Electronics products have been tested and are certified by Sensor Electronics to accurately process date/time and date/time related data from, into and between the 20th and 21st centuries. Sensor Electronics products neither contain nor create any logical or mathematical inconsistency, will not malfunction, and will not cease to function when processing date/time data.

Please contact Sensor Electronics for further information.

Table of Contents

- I. SPECIFICATIONS
- II. GENERAL DESCRIPTION
 - Features
 - Theory of Operation
- III. INSTALLATION
 - Mechanical
 - Electrical
- IV. CALIBRATION / OPERATION
 - Zeroing
 - Warm Up
 - Normal
 - Spanning
 - Calibration Certification
- V. PARTS LIST
- VI. DRAWING SECTION
 - Figure 1 Dimensions/Wiring
 - Figure 2 Mounting
 - Figure 3 PC Link Wiring
 - Figure 4 Sensor Separation Kit

I. SPECIFICATIONS

Model: SEC Signature DIR **Part Number:** DIR011021000000 (No Pressure compensation)
Part Number: (With Pressure Compensation) (Available April 06)

Measuring Range: EtO Channel: 0-2000 milligrams/liter (maximum)
Factory calibrated to 0-1000 mg/l EtO
H2O Channel: 0-500 milligrams/liter (maximum)
Factory calibrated to 0-300mg/l H2O

Detection Method: Diffusion

Construction: Housing is anodized aluminum with sapphire windows.

Rating: Class 1, Division 1, Groups BCD (pending)
Atex Zone 1 (pending)

Accuracy: +/- 5% measured value or +/- 3% full scale (whichever greater)

Repeatability: +/- 3%

Operating Temperature Rating: +0°C to +75°C (maximum)
+32°F to +167°F (maximum)

Operating Voltage: 24 VDC. Operating range 18 to 32 VDC measured at the detector head.

Outputs (analog): 4-20 mA (Source type), max. 1000 Ohm load at 24 VDC supply voltage.

Output (digital): Interactive PC Link

Power Consumption at 24 VDC: 35 watts (Max)

Current Draw at 24 VDC: 1A (average)

Mechanical connection to sterilizer: 3/4" NPT male

Electrical connection: 3/4" NPT male

Weight: 30 ounces

Wire Connections: Red wire (+ 24 VDC)
Black wire (D.C. common)
Blue wire (4-20 output EtO)
Yellow Wire (4-20mA output H2O)
White wire (Calibration / digital interface)

II. GENERAL DESCRIPTION

The SEC Signature DIR Process monitor is a microprocessor based intelligent device that continuously and simultaneously monitors levels of EtO and H₂O in sterilization chambers.

The SEC Signature DIR Process monitor is a stand-alone device providing a dedicated 4-20 mA signal corresponding to actual concentrations of ethylene oxide and a dedicated 4-20mA signal corresponding to the actual concentration of H₂O.

Features

- Programmable Heater operates in Relative or Closed Loop Mode.
- Continuous self-test automatically indicates a fault, with fail to safe operation.
- A multi-layered filtering system protects optics from dirt and water ingress.
- Straight optical path eliminates the need for mirrors, reflective surfaces or beam splitters thereby increasing the stability and reducing the maintenance of the device.
- Discourages condensation interference by internally heating optical chamber.
- Standard 4 to 20 mA outputs (current sources).
- Explosion proof housing designed for duty in harsh environments.
- Smart Calibration AutoAC™ circuit.

Theory of Operation

The SEC Signature DIR Process monitor uses infrared absorption technology for detecting target gas concentrations. Gases absorb infrared light only at certain wavelengths. The concentration of a gas can be measured by the difference of two channels (wavelengths), a reference and a measurement channel. The SEC Signature DIR Process monitor uses an infrared light source at one end and a dual channel receiver at the opposite end. The dual channel receiver measures the intensity of two specific wavelengths, one at an absorption wavelength and another outside of the absorption wavelength. The gas concentration is determined by a comparison of these two values.

The multi channel receivers incorporate single wafer double filter technology with internal optical barriers. The elements are perfectly matched resulting in overall stability and superior performance throughout the entire temperature range. By using this multi channel receiver there is no need to use any special lenses or beam splitters to achieve the dual measurement bands.

The SEC Signature DIR Process monitor utilizes a unique Automatic Analog Control circuit, the AutoAC™ circuit (Patent Pending). The AutoAC™ continuously makes adjustments to null out effects from temperature, component drift, dirty optics, interferences and aging. These adjustments are made according to algorithms derived from infrared gas absorption theory. The AutoAC™ circuit is continuously checking all unit operating parameters. If any parameter goes out of tolerance, the AutoAC™ circuit sets a fault code appropriate to the problem. The AutoAC™ circuit ensures that once the unit is spanned, it will remain accurate as long as the zero is accurate. Simply calibrate (span one time) the unit with a specific amount of gas and the device will repeatably track the gas concentrations in the chamber throughout the entire load cycle. The only ongoing calibration that is necessary is an occasional zero.

The optical absorption efficiency of water vapor is a function of the chamber pressure. Higher chamber pressures cause more absorption resulting in higher signal levels.

The H₂O channel is designed to be accurate with pressure rise due to the vapor pressure of the H₂O in the chamber.

Pressure rise due to N₂ EtO injections will cause higher H₂O readings. Therefore, the H₂O signal will be accurate as long as the chamber contains only water vapor.

If accurate readings are required throughout the entire cycle, pressure compensation will be necessary. Pressure compensation is achieved by adding the pressure compensation option and using a dedicated absolute pressure sensor mounted close to the sensor. The 4-20mA output from the pressure sensor is connected to the sensor's pressure input wire.

III. INSTALLATION

Mechanical

The SEC Signature DIR Process monitor has a 3/4" male NPT threaded connector for installing the device on the sterilizer. Ideally the device can be installed on the recirculation line (see Figure 4). The device is vacuum tested at the factory to 1 inches of mercury absolute and pressure tested to 40 psi.

Electrical

The SEC Signature DIR Process monitor has a 3/4" male NPT threaded connector (with 4 wires) for mounting the detector to a junction box. SEC can provide a junction box for this purpose with terminals (see Figure 5).

A user-supplied junction box can also be used, providing it has the appropriate sized NPT conduit entries. This junction box must be suitable for use in the application and location in which it is being installed.

Wiring connections

| | |
|--------------|------------------------------------|
| Red wire: | 18 to 32 VDC |
| Black wire: | DC negative (common) |
| Blue wire: | 4 to 20 mA output EtO |
| Yellow wire: | 4 to 20 mA output H2O |
| White wire: | Smart Calibration Wire (data wire) |

Refer to Figures 2 and 3 for general wiring details.

Insulator

The SEC DIR Signature internal temperature should be at least 6° C warmer than the process temperature. Temperature rise can be adjusted by adjusting heater level. *The internal temperature of the Signature DIR can be adjusted and monitored using the SEC IR PC LINK software package.* If more temperature rise is needed with heater at full power, it may be necessary to insulate sensor.

IV. OPERATION

Warm-up

When power is applied to the detector, it enters a one (1) minute warm-up mode in which time it performs diagnostic checks and allows the sensor to stabilize before beginning normal operation. The current output during this period is 0.8 milliamperes. At the end of the warm-up period with no faults present, the detector automatically enters the normal operating mode. If a fault is present after warm-up, the detector current output will indicate the fault (see chart above).

Normal

In the normal operating mode, the 4 to 20 mA signal levels correspond to the detected gas concentrations. The device continuously performs self diagnostics, checks for calibration requests and displays operating status (see table).

Calibration

Calibration operations and Parameter download are accomplished via the Sensor's white wire.

White wire is connected to Data Translator (SEC IR PC Link P/N 1420636)

Data Translator is connected to PC via serial port. Operating from USB port requires a USB to serial converter.

Commands are issued from PC (Software Package Supplied by SEC)

The software is compatible with most versions of Microsoft® Windows®

Note: For best accuracy, the unit should be powered up for at least 1 hour before any calibration operation.

Zeroing

EtO (Channel 0)

Zeroing should be performed:

When unit is installed on chamber

If Sensor doesn't return to zero between cycles

If Sensor shows abnormally high or low concentration readings during EtO exposure.

Annually (more often if the load material is dusty or oily)

Procedure:

After chamber evacuation, water injection and dwell:

Move cursor to "Zero EtO Channel" using "Up/Down" arrows

<enter>

Zero Channel 0 ? (Y/N)

<Y><enter> will initiate Zero Operation

The EtO output goes to 2.2mA while Zeroing.

A successful Zero will result in 4.0mA

An unsuccessful Zero will result in a 4-20mA fault level. (<4mA) See Status table.

H2O (Channel 1)

Zeroing should be performed:

When unit is installed on chamber.

If sensor shows abnormally high or low concentration readings during H2O exposure.

Annually (more often if the load material is dusty or oily)

Procedure:

It is very difficult to remove water from the chamber. Even after several N2 washes and evacuations, enough water remains in the chamber to skew the zero. The best way to ensure an accurate zero is to apply dry N2 directly to the sensor either in the chamber or removed from the chamber.

Procedure:

Move cursor to "Zero H2O Channel" using "Up/Down" arrows

<enter>

Zero Channel 1? (Y/N)

<Y><enter> will initiate Zero Operation

The H2O output goes to 2.2mA while Zeroing.

A successful Zero will result in 4.0mA

An unsuccessful Zero will result in a 4-20mA fault level. (<4mA) See Status table.

Note: For best accuracy, the unit should be powered up for at least 1 hour before any calibration operation.

Note: When calibrating with the sensor removed from chamber, best accuracy is obtained by calibrating with the sensor in the same physical orientation as when installed on chamber.

Current Output and Corresponding Status Table

| Current Output | Status |
|----------------|--------------------------|
| 4-20 mA | Normal measuring mode |
| 0.0 mA | Unit Fault |
| 0.2 mA | Reference channel fault |
| 0.4 mA | Analytical channel fault |
| 0.8 mA | Unit warm up |
| 1.0 mA | Optics fault |
| 1.2 mA | Zero drift fault |
| 1.6 mA | Calibration fault |
| 2.0 mA | Unit spanning |
| 2.2 mA | Unit zeroing |
| 4.0 mA | Zero gas level |
| 20 mA | Full scale |

The 4 to 20 mA outputs are non-isolated current sources.

Spanning

Spanning is only required to establish measurement range. Spanning teaches the unit what ½ of full scale looks like.

The unit is designed to be spanned at the typical empty chamber operating concentration. The fact that the span value becomes ½ of full scale gives the unit over-range capability. This is important since certain loads will cause the EtO concentration (in the headspace) to spike much higher than the theoretical concentration right after injection. Over-range capability allows the unit to track concentrations through the spikes.

The span will only be as accurate as the Zero point. **Spanning should always be preceded with Zeroing.**

The span point becomes the mid range point of the SEC DIR Signature Process monitor.

(Example) When the EtO channel is spanned at 520 mg/l, full scale range is 0 to 1040 mg/l.

EtO(Channel 0)

The EtO channel is factory coarse spanned with ethylene span gas to a range of 0-1000 mg/l EtO.

Spanning should be performed:

If abnormally high or low EtO readings are observed during EtO exposure and re-zeroing didn't resolve the problem.

If the unit needs to be ranged for a different full scale concentration.

Procedure:

Perform Zero Operation.

Introduce desired EtO concentration into chamber and let equilibrate.

Move cursor to "Span EtO Channel" using "Up/Down" arrows

<enter>

Span Channel 0 ? (Y/N)

<Y><enter> will initiate Span Operation

The EtO output goes to 2.0mA while Spanning.

A successful Span will result in 12mA

An unsuccessful Span will result in a 4-20mA fault level. (<4mA) See Status table.

H2O(Channel 1)

The H2O channel is factory coarse spanned with CO2 span gas to a range of 0-300 mg/l H2O.

Spanning should be performed:

If abnormally high or low H2O readings are observed during H2O exposure and re-zeroing didn't resolve the problem. (Be aware of pressure response that could be skewing your readings)

If the unit needs to be ranged for a different full scale concentration.

Procedure:

Perform Zero Operation.

Introduce desired H2O concentration into chamber and let equilibrate.

Move cursor to "Span H2O Channel" using "Up/Down" arrows

<enter>

Span Channel 0 ? (Y/N)

<Y><enter> will initiate Span Operation

The H2O output goes to 2.0mA while Spanning.

A successful Span will result in 12mA

An unsuccessful Span will result in a 4-20mA fault level. (<4mA) See Status table.

Note: For best accuracy, the unit should be powered up for at least 1 hour before any calibration operation.

Heater Adjustment

Relative Mode (Recommended)

In the Relative Mode, a constant power level is applied to the heaters. This will give the best accuracy over process temperature variations. There are 10 fixed power levels; 0=heaters off, 10=Full Power.

The sensor temperature is a function of process temperature, mounting surface temperature, and ambient temperature. Therefore, an empirical method is the best way to set the heater level.

Procedure:

To adjust heater, select "Heater Level"

The heater mode will be displayed (Relative)

Followed by the current Heater Level

Followed by "Change Power Level? (Y/N)"

<Y><enter>

"New Heater Level: "

Enter Heater Level and <return>

Closed Loop Mode

In the Closed Loop Mode, a target temperature set by user and the heater level is automatically adjusted to keep the sensor temperature at the target temperature.

Procedure:

To adjust target temperature, select "Heater Level"

The heater mode will be displayed (Closed Loop)

Followed by the current Target Temp

Followed by "Change Target Temp? (Y/N)"

<Y><enter>

"New Target Temp: "

Enter Target Temp and <return>

Calibration Certification

Document: 7305 Rev. 1.001

Customer:

Sales Order:

Ship Date:

| SEC Signature DIR Serial # | Channel | Cal Date | Cal Gas Value | Span Hex Value | Check Sum (Linearization) | Firmware Rev |
|-------------------------------|------------------|----------|---|----------------|------------------------------|--------------|
| | Channel 0 EtO | | 70% Volume Ethylene +/-2% NIST Traceable | | | |
| | Channel 1 H2O | | 78% Volume CO2 +/-2% NIST Traceable | | | |

Calibration Procedure: 7304

Test Procedure: 7302

TEST PERSON SIGNATURE

PRINT NAME

DATE

70%V/V Ethylene generates a unit response approximately equivalent to 500 mg/l ethylene oxide. This results in a range of 0-1000mg/l.

78%V/V CO2 generates a unit response approximately equivalent to 150 mg/l water vapor. This results in a range of 0-300mg/l.

Best accuracy requires the unit to be zeroed and spanned in-chamber at operating temperature and humidity, using typical concentrations of EtO and H2O for spanning.

Example of Calibration Certification

Each SEC Signature is shipped with a completed Calibration Certification.

V. PARTS LIST

| Part Number | Description |
|-----------------|---------------------------------------|
| DIR011021000000 | SEC Signature DIR Process monitor |
| 142-1750 | SEC DIR PC Link Kit |
| 190-10001 | SEC 2001 Explosion proof junction box |
| 142-0852 | Replacement Screen |
| 142-0701 | Replacement Filter |

VI. DRAWING SECTION

| Figure # | Title |
|----------|-----------------------|
| Figure 1 | Dimensions/Wiring |
| Figure 2 | Mounting |
| Figure 3 | PC Link Wiring |
| Figure 4 | Sensor Separation Kit |

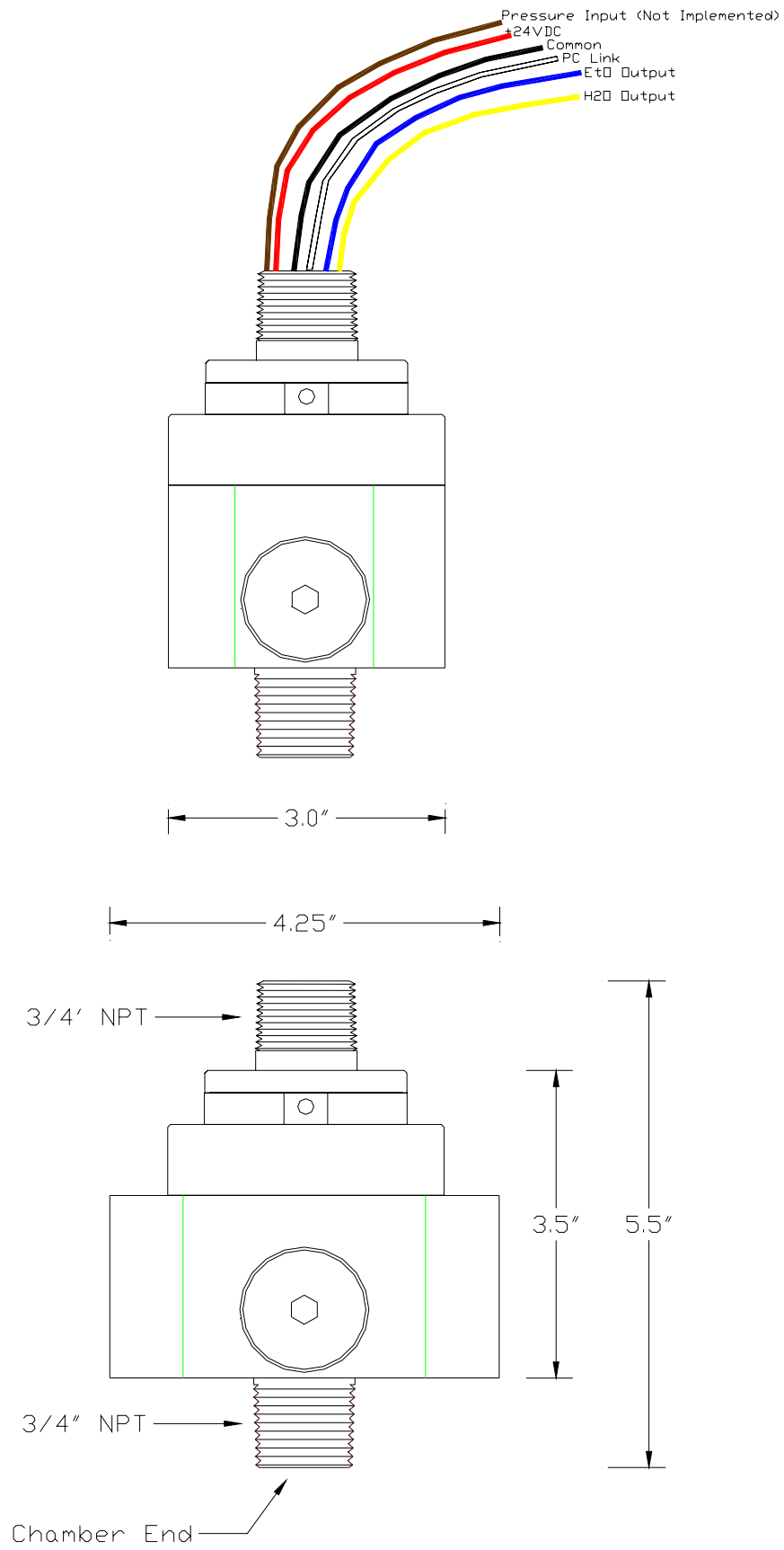

Figure 1

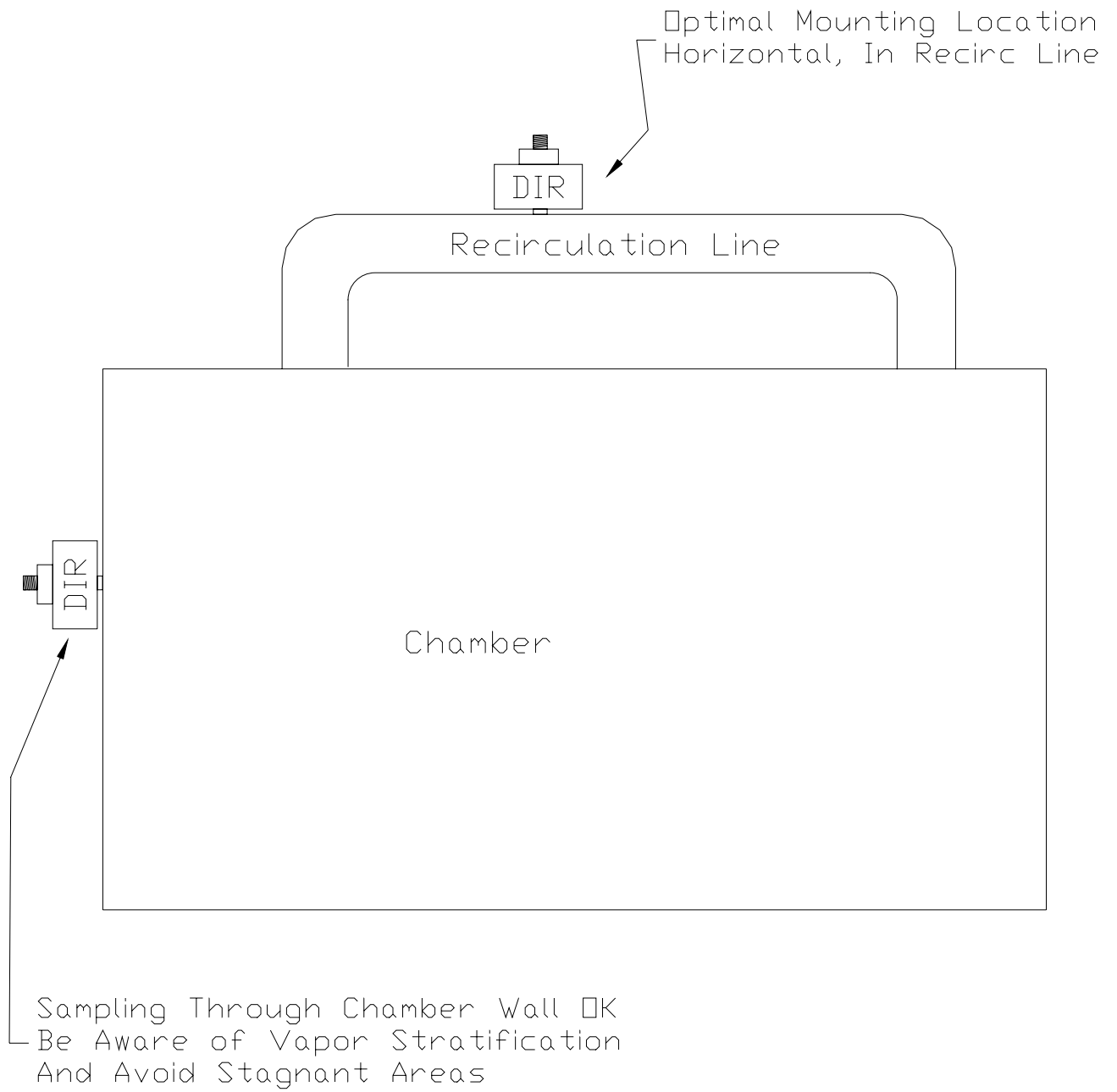

Figure 2

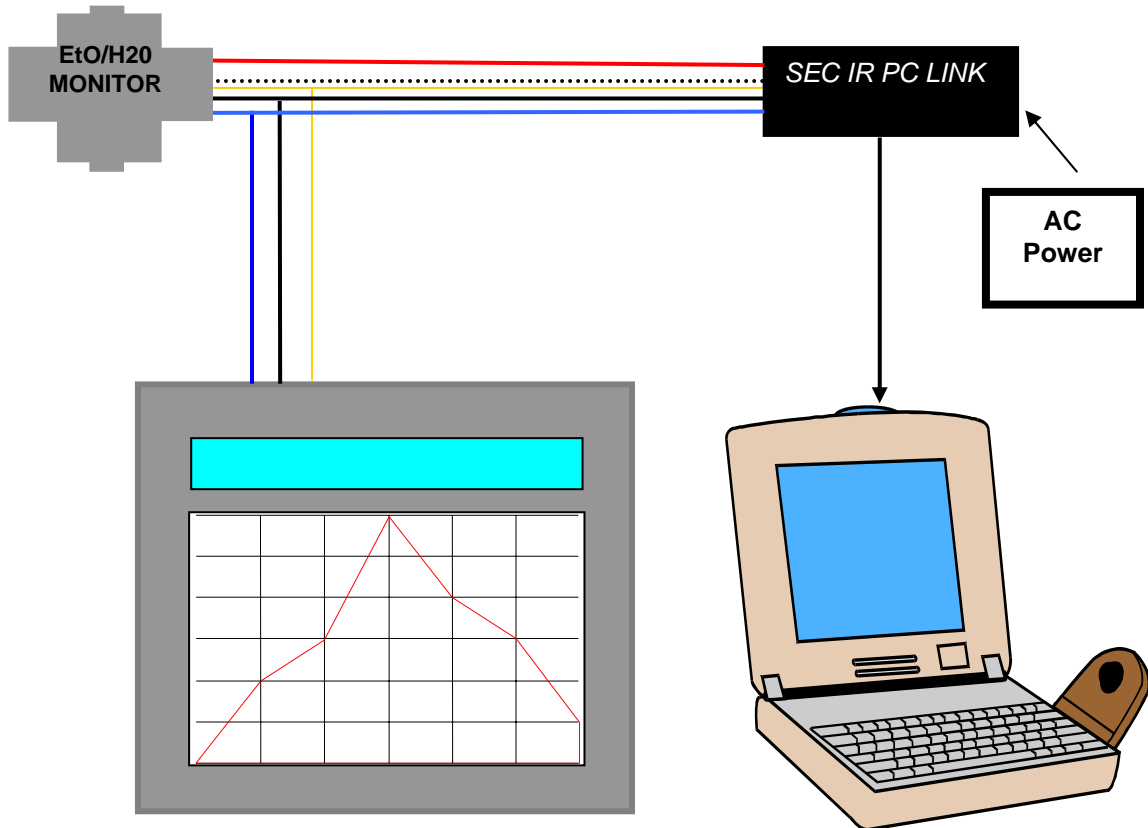

Chart Recorder
PLC, DAS, DCS, DVM
(Any control or monitoring system that accepts a 4-20 mA or 0-5 VDC signal)

Figure 3

Figure 4

